

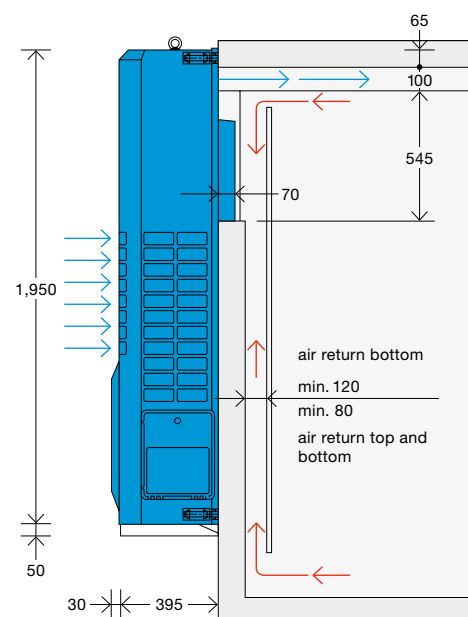

- 1 Easy maintenance:** Accessibility to all unit components by hinging the refrigeration machine open, even when vehicle is loaded.
- 2 Quick release fasteners:** Only one electrical plug-in connection. Automatically closing refrigerant couplings, also for additional connections for multi-temperature systems or additional cold holdover system with eutectic beams. Unit exchange within minutes, thus increasing the operational readiness of the refrigeration machine to up to 100%.
- 3 Loss-free electrical control** for alternator and mains operation using reliable electric relays. Easy thermostatic stop/start of the compressor with continuously running evaporator fan. Fuel consumption and wear reduced by up to 50%, also when compared to the start/stop operation of a diesel engine; remote control from driver's cabin.
- 4 No diesel engine in the refrigeration unit:** Thereby space for extremely large heat exchanger surfaces with low-pressure levels. Increased life-time of the refrigeration compressor with considerably lower energy consumption, exhaust and noise emissions.
- 5 Only one low-wear, short, direct V-belt drive:** Straight belt runs use of standard V-belts.
- 6 Two low speed, low noise fans:** Further speed and noise level reduction with L-speed or 2-speed SL-version option.
- 7 GRP plastic housing:** Extremely robust, noise absorbing and lightweight.
- 8 Frames made of special high-strength aluminium sections with stainless steel bolts:** Maintenance-friendly also after many years of operation on dirty roads and of exposure to de-icing salt.
- 9 Evaporator completely outside the vehicle box:** No risk of damage of fridge unit/goods inside the vehicle box. Robust fan drive by directly coupled 3-phase motors, no carbon brush or V-belt wear. Large evaporator with doubled fin spacing, high efficiency, delayed icing.
- 10 Special FRIGOBLOCK designed electric motor with high capacity reserves:** Safe running over whole speed range of the alternator. Large ball bearings regreasable for extremely long life-time.
- 11 Crossflow fan with longest air throw:** Constant maximum air volume, uniform through-flow of the total vehicle box. Air discharge height only 100 mm, thus allowing double deck loading up to the bulkhead without any loss of loading height.
- 12 Robust, long-life refrigeration compressor with oil pump:** Designed for the high capacity refrigerant R410A. High operational reliability and efficiency, speed range between 500 and 3,000 rpm. Unsurpassed volumetric efficiency, low energy consumption. No increase of the critical discharge temperature by the waste heat of a diesel engine.
- 13 No failure-prone flexible refrigerant hoses:** Vibration-free alternator drive system.
- 14 High capacity refrigerant R410A:** 20% less energy consumption and 80% less global warming potential. Highest refrigeration capacities, box temperatures down to -40°C, no reduced capacity with mains operation.
- 15 Extremely quick 4-way hot gas system:** No 3-way bypass circuit. Defrosting and re-cooling within 5 to 10 minutes. Optional: reliable electric heating, maximum heating capacity even with lowest ambient temperatures.

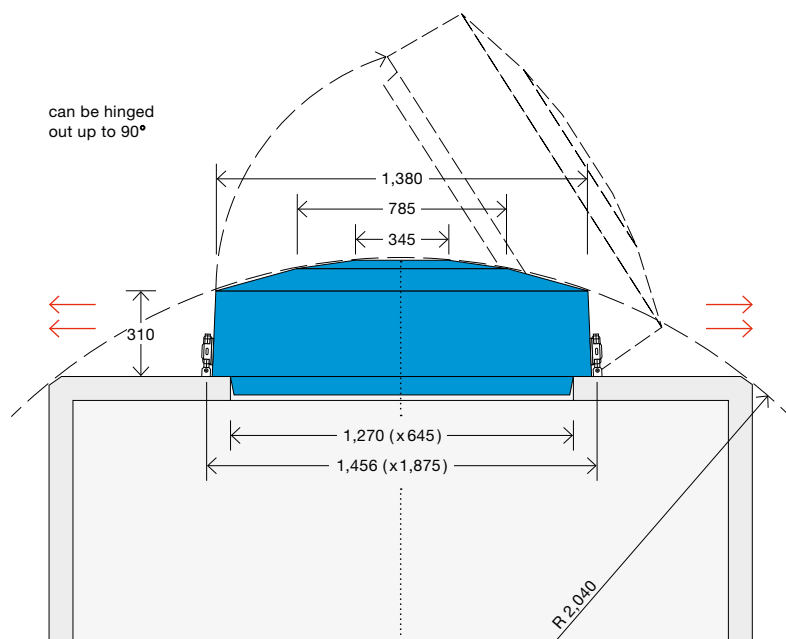

TECHNICAL SPECIFICATIONS HK 23/24/25

FRIGOBLOCK Type	HK 23	HK 24	HK 25 L	HK 25	HK 25 SL	DIM.
Refrigeration capacity at +30 °C ambient temperature						
box temperature at 0°C	14,500	17,500	16,600	21,100	23,300	W
box temperature at -20°C	7,800	9,200	8,500	11,100	13,100	W
box temperature at -30°C	5,100	6,000	5,200	6,900	8,500	W
Heating capacity						
heat pump system up to	24,000	30,000	28,000	35,000	40,000	W
electric heaters	6,100	6,100	6,100	8,600	8,600	W
Refrigerant						
HFC	R410A	R410A	R410A	R410A	R410A	
Compressor						
cylinders	2	2	4	4	4	
piston displacement	24.8	30.1	32.4	40.5	48.8	m³/h
rpm	1,760	1,800	1,160	1,450	1,750	1/min
Electric motor						
capacity	7.5	9	7.5	11	13	kW
rpm	1,450	1,450	1,450	1,450	2,900	1/min
Evaporator						
surface area	66.2	66.2	66.2	66.2	66.2	m²
crossflow fan Ø x L	160x1,040	160x1,040	160x1,040	160x1,040	160x1,040	mm
motor capacity	1,100	1,100	1,100	1,100	1,100	W
air capacity	5,200	5,200	5,200	5,200	5,200	m³/h
air velocity	15-20	15-20	15-20	15-20	15-20	m/sec
air throw, without duct	9-10	9-10	9-10	9-10	9-10	m
Condenser						
surface area	70.2	70.2	70.2	70.2	70.2	m²
axial fans Ø	440/440	440/440	440/440	440/440	440/440	mm
motor capacity	2 x 370	2 x 370	2 x 370	2 x 370	2 x 370	W
3-phase alternator						
capacity	17	24	17	24	24	kVA
Mains						
fuse protection (slow)	25	25	25	25	35	A
Weight						
refrigeration unit	290	300	310	310	310	kg
alternator	76	98	76	98	98	kg

Capacities at 60% of the rated vehicle engine speed or on mains operation, 400/415 V, 50 Hz.

Subject to technical changes without prior notice.